

HALFEN HCC COLUMN SHOE

TECHNICAL PRODUCT INFORMATION



HALFEN COLUMN SHOE

HCC 09-E

CONCRETE



HALFEN
YOUR BEST CONNECTIONS

HALFEN COLUMN SHOE SYSTEM

Introduction

The better solution for connecting precast columns

HALFEN HCC column shoe combined with HALFEN HAB Anchor bolts

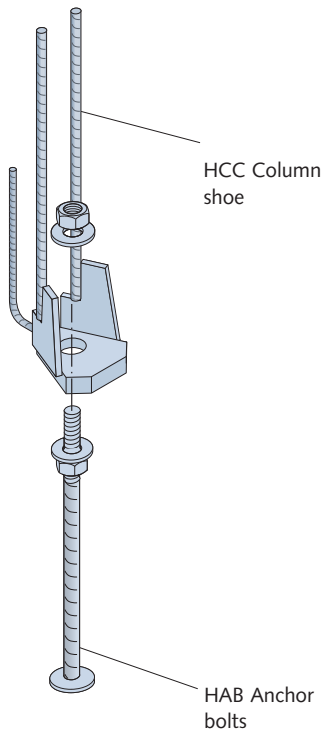

These days, there's a significantly more economical way to assemble precast columns. The new HALFEN HCC Column shoe provides a convenient solution for connection to foundations or for linking columns together. One advantage of the prefabricated system with screw connection is its rapid assembly. The connection is simple to adjust and immediately load bearing. This means no assembly braces are necessary and crane occupancy is optimised. The system comprises the HCC Column shoe and the respective HAB Anchor bolts for the anchoring base. The principle: The column shoes are set into the precast columns, the anchor bolts into the foundation on site, using a template. During assembly, the elements are connected together mechanically using nuts. In the final step the remaining recesses and the foot of the column are filled with low-shrink seal mortar.

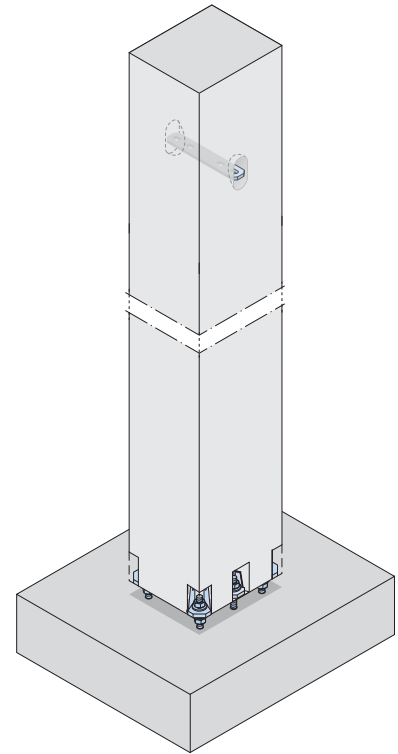

Column connection, designed for normal force and bending moment loads.

Application

• Arrangement in the column

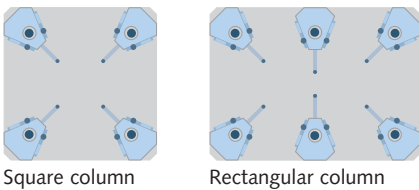

Square column

Rectangular column

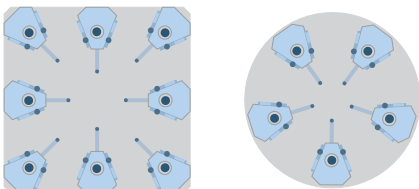

Highly stressed square column

Round column

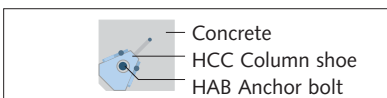

• Fitting the HALFEN HAB Anchor bolts

The anchor bolts must be fitted exactly according to the position and arrangement specified in the design drawings.

The use of a fitting template is recommended to ensure that the anchor bolts are exactly located according to dimensions; and to prevent displacement during concreting and compacting.

Fitting templates → page 13.

• Fitting the HALFEN HCC Column shoes. Fixing sets for fixing the column shoes in the concrete formwork are available as accessories → page 12.

• Mounting the precast columns
Adjust vertically, align, screw tight, cast the joint → page 13.

Dimensioning software for structural design and type selection → pages 4-5

HALFEN COLUMN SHOE SYSTEM

Column shoe combinations, product variants

HCC Column shoe, combined with single HAB Anchor bolts

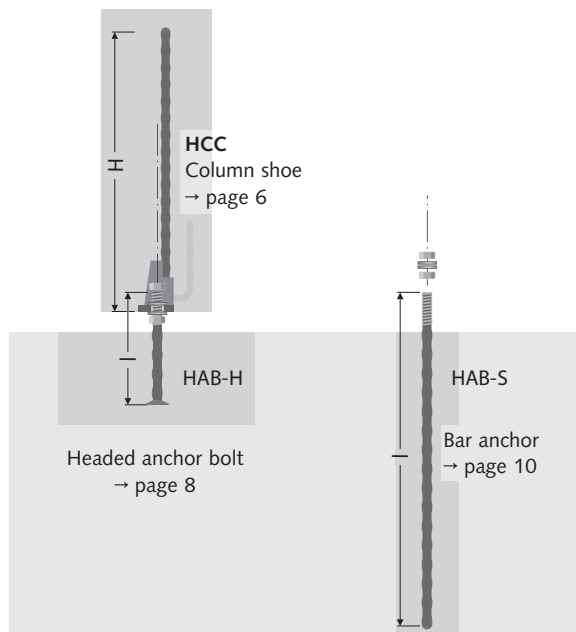

Special forms such as bent or angled anchor bolts are available on request.

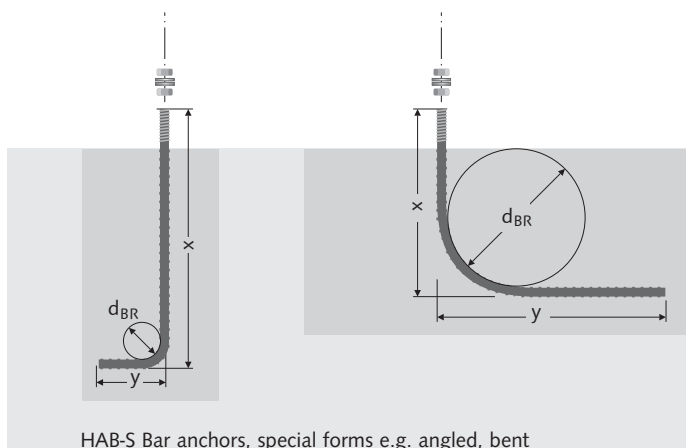

HCC-M Column shoe, combined with multiple HAB Anchor bolts

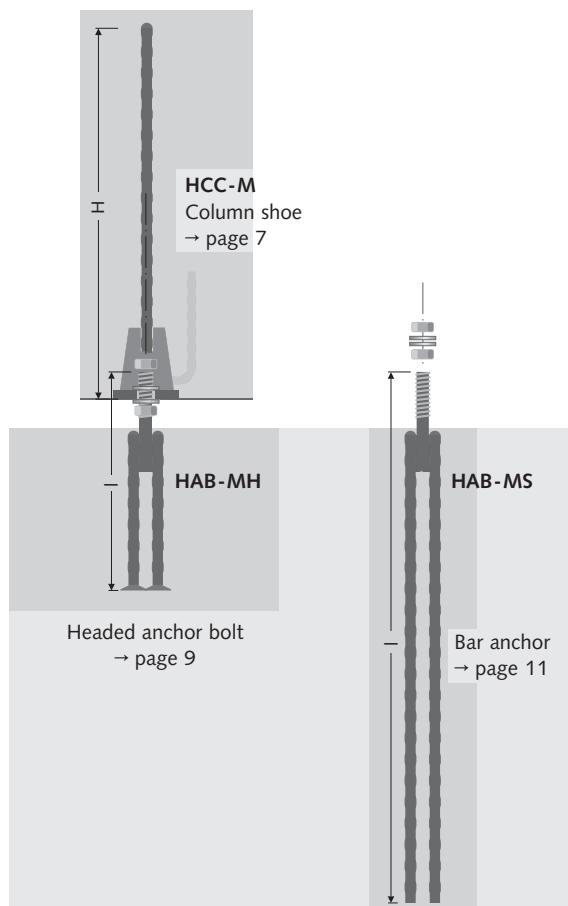

Special forms such as bent or angled anchor bolts are available on request.

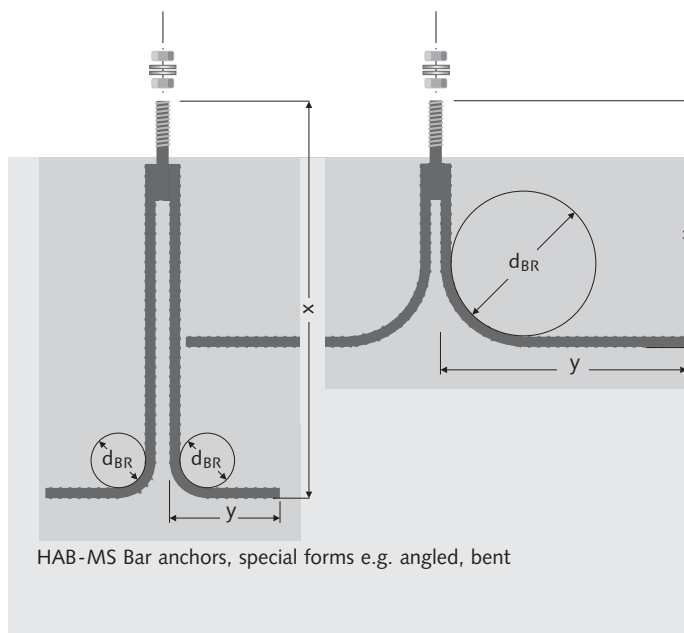

HALFEN COLUMN SHOE SYSTEM

Dimensioning software

HCC Column shoes, HAB Anchor bolts

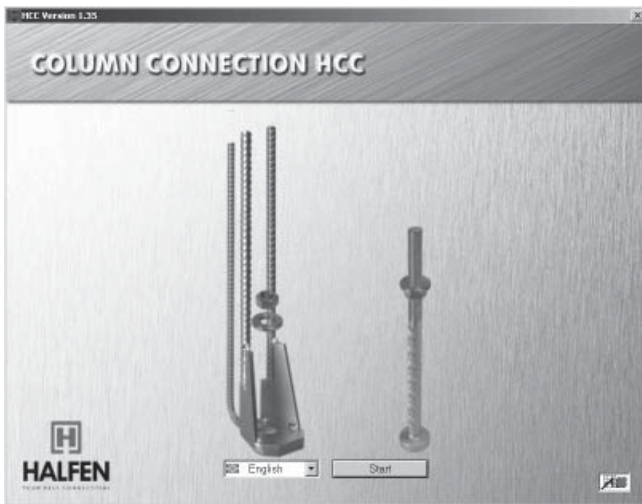

Start window

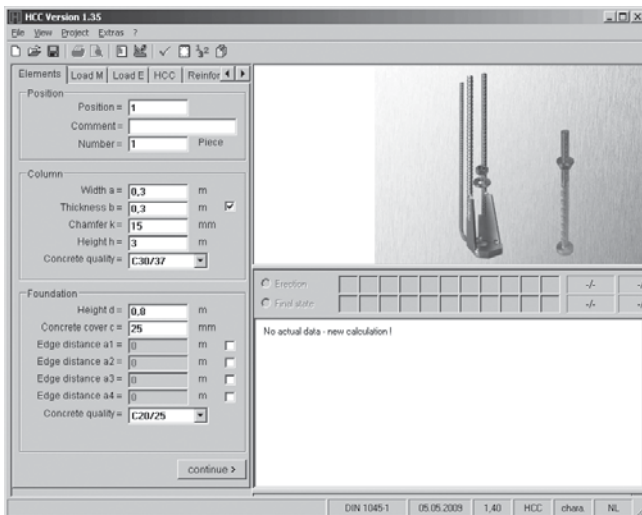

Geometry and material

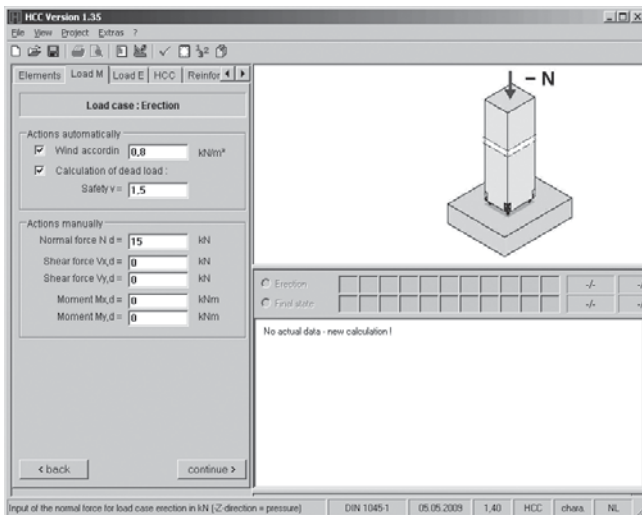

Impacts in the state of assembly

A user-friendly software is available for the selection and dimensioning of the required HAB Anchor bolts and HCC Column shoes. It allows the calculation of the loads of the HALFEN HCC Column shoes for both the conditions during assembly and the final state.

With the help of the module for double bending combined with axial force the maximum load on the column shoe is determined. The software also calculates the anchoring of the HAB Anchor bolts according to the official approvals. The selection of the anchor diameter can be effected automatically or by preselection.

Screen for entering data about position, dimensions of the structural members, edge distances and the concrete strengths, of the column and the foundation. During the input the appropriate auxiliary texts are displayed in the status bar.

Input screen to consider impacts during assembly, with the following options:

- automatic calculation with wind load and dead load;
- calculation with input of the applicable loads.

HALFEN COLUMN SHOE SYSTEM

Dimensioning software

HCC Column shoes, HAB Anchor bolts

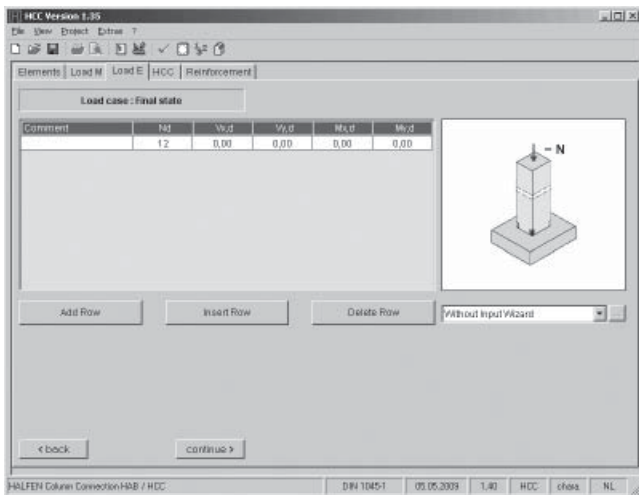

Impacts in the final state

All impacts for the load case 'final state' can be entered here. The load cases for design loads can be defined individually. Alternatively 2 input assistants are available, which are useful for generating any combination of permanent and variable loads or for any load cases, which can be defined fully out of limits.

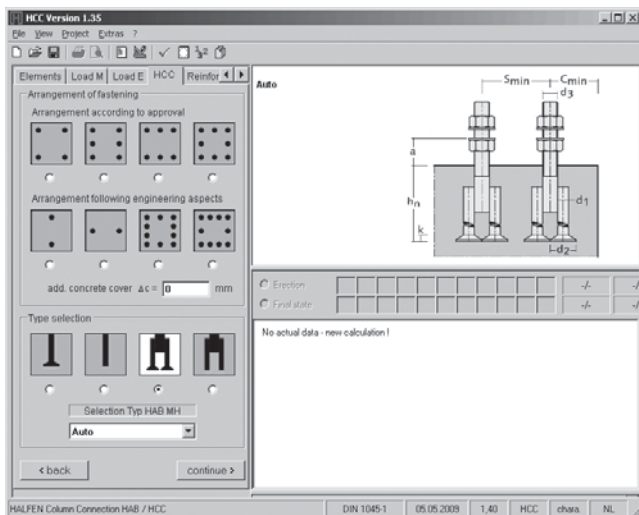

Arrangement and type of HALFEN anchor bolts

The total number of anchor bolts and the arrangement within the bolt group can be chosen as well as the type of anchor bolt. Additional concrete cover can be set. The load group can be preselected or determined by the software.

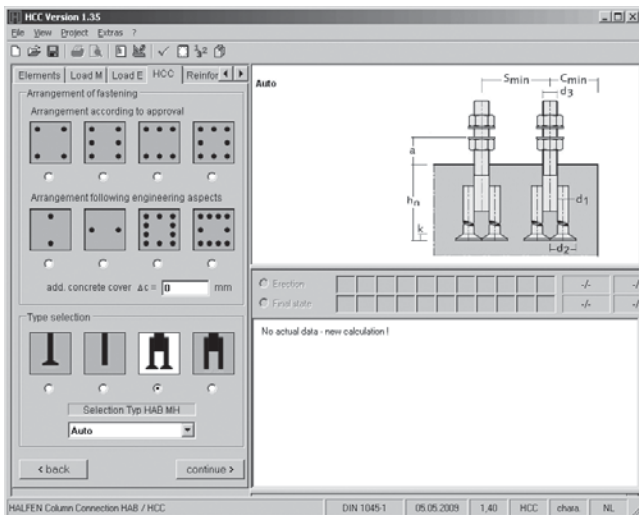

Results

After completion of the calculation, the status for all values is displayed individually. The results can be checked on screen. The position of the neutral line is displayed. Of course the detailed results, and a parts list for the whole project can be printed on any common printer.

HALFEN COLUMN SHOE SYSTEM

Column shoe

Column shoe type HCC

HALFEN HCC Column shoe

HALFEN Column shoes type HCC are connection parts to form rigid column connections and joints. The rigid connection is effective both during assembly and in the final state. The internal forces which occur are passed into the anchorage base by the HALFEN Anchor bolts HAB-H (headed anchor bolts) or HAB-S (straight anchor bolts).

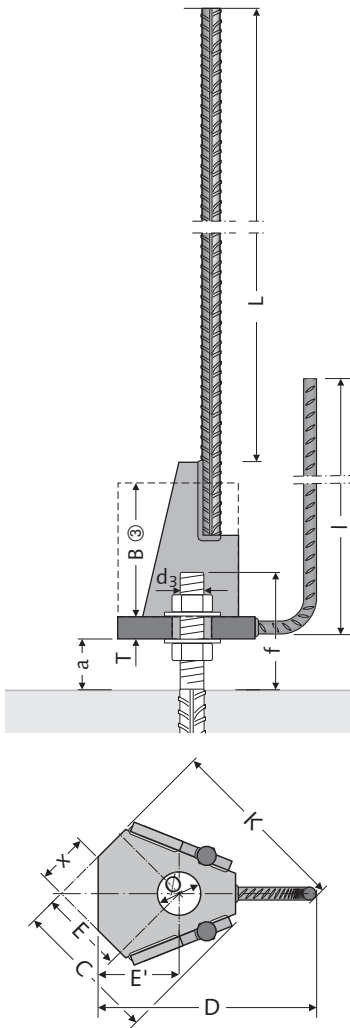

Type selection HCC

Item name HCC d3- L ② Type [mm] - [mm]	Article no.	Dimensions, fitting measurements [mm]										Weight [kg/ piece]	
		B③	C	D	E	x	K	Ø	T	l	a		f
HCC 16- 640	00001	80	87	135	50	30	112	27	15	300	50	105	2.3
HCC 20- 830	00002	90	95	142	50	30	117	30	20	450	50	115	3.8
HCC 24- 905	00003	100	106	150	50	30	123	35	25	550	50	130	5.8
HCC 30-1100	00004	115	119	188	50	30	150	40	35	800	50	150	11.0
HCC 39-1450	00005	145	157	245	60	37	195	55	45	900	50	165	26.5

Load bearing capacity HCC

Item name HCC d3- L ② Type [mm] - [mm]	Suitable anchor bolts:		Design value tensile stress $N_{Rd,s}$ ① [kN]	Max. eccentricity = assembly tolerance e [mm]
	with headed anchor bolt	straight anchor bolt		
HCC 16- 640	HAB-H16	HAB-S16	61.7	± 5
HCC 20- 830	HAB-H20	HAB-S20	96.3	± 5
HCC 24- 905	HAB-H24	HAB-S24	138.7	± 5
HCC 30-1100	HAB-H30	HAB-S30	220.4	± 5
HCC 39-1450	HAB-H39	HAB-S39	383.4	± 8

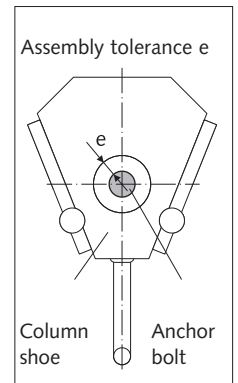

Combination with anchor bolt

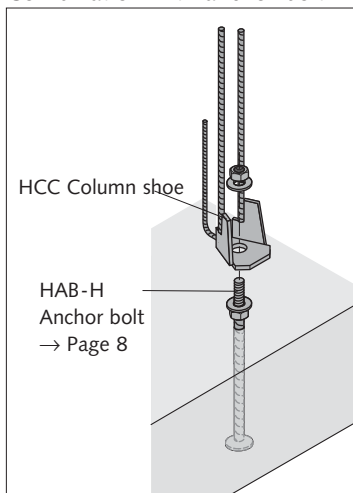

- ① for column concrete \geq C30/37 acc. to type test certificate. Additional reinforcement and execution of the lap-over joint for column reinforcement → page 12
- ② Length L for 'good' anchorage conditions (incl. $1.0 \times f_{bd}$, VB I). Also available for 'poor' anchorage conditions on request (incl. $0.7 \times f_{bd}$).
- ③ Dimension B corresponds to the height of the recess body → page 12.

When designing the column connection, the basic conditions of type test certificate no. 03.30 (for HCC and HCC-M) and approvals Z-21.5-1761 (for HAB-H) and Z.21.5-1758 (for HAB-MH) must be taken into consideration.

HALFEN provides the HCC dimensioning software as a working aid → page 4-5.

TECHNICAL CONSULTATION

HALFEN is represented with sales offices and distributors worldwide. Please contact us: www.halfen.com → refer to catalogue rear cover.

Materials, standards

Base plate, side plates	S355J2, DIN EN 10025-2
Reinforcement steel	BSt 500S, DIN 488-1; (B 500B)

HALFEN COLUMN SHOE SYSTEM

Column shoe

Column shoe type HCC-M

HALFEN HCC-M Column shoe

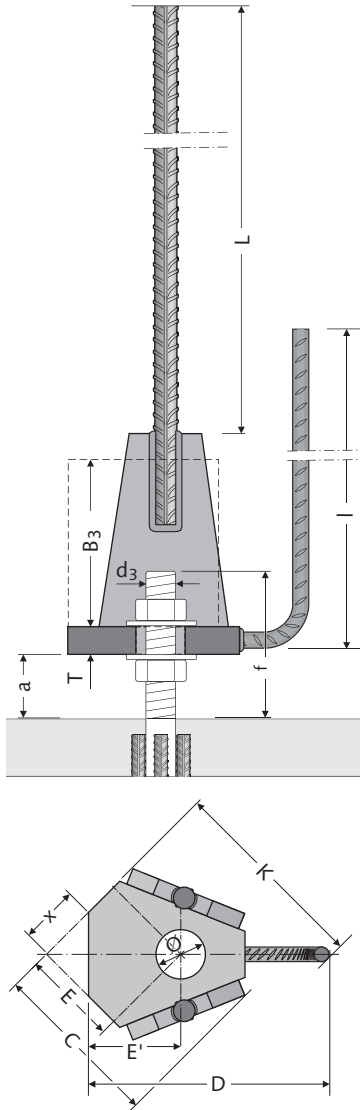

Combination with anchor bolt

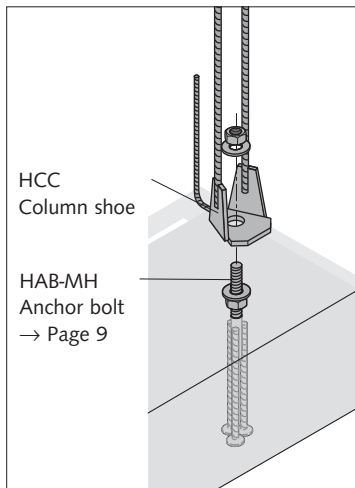

HALFEN Column shoes type HCC-M are connecting parts to form rigid column connections for higher stressed construction members. The rigid connection is effective both during assembly and in the final state. The internal forces which occur are passed into the anchorage base by the HALFEN Anchor bolts HAB-MH (headed anchor bolts) or HAB-MS (straight anchor bolts).

Type selection HCC-M

Item name HCC-M d3- L ② Type [mm] - [mm]	Article no.	Dimensions, fitting measurements [mm]										Weight [kg/ piece]	
		B③	C	D	E	x	K	Ø	T	l	a		f
HCC-M30 - 1200	00006	125	134	220	50	30	173	45	45	1050	50	165	18.5
HCC-M36 - 1650	00007	155	157	245	60	37	195	55	50	1000	55	165	29.0
HCC-M39 - 1650	00008	175	172	267	60	37	210	55	55	1000	55	185	40.5
HCC-M45 - 2070	00009	175	207	317	60	37	246	65	60	1460	65	195	69.0
HCC-M52 - 2290	00010	175	232	366	60	35	280	70	70	1450	70	240	95.0

Load bearing capacity HCC-M

Item name HCC-M d3- L ② Type [mm] - [mm]	Suitable anchor bolts:		Design value tensile stress $N_{Rd,s}$ ① [kN]	Max. eccentricity = assembly tolerance e [mm]
	with headed anchor bolt	straight anchor bolt		
HCC-M30 - 1200	HAB-MH30-(36)	HAB-MS30-(36)	299	± 4.5
HCC-M36 - 1650	HAB-MH36w	HAB-MS36	436	± 9.5
HCC-M39 - 1650	HAB-MH39	HAB-MS39	520	± 8
HCC-M45 - 2070	HAB-MH45	HAB-MS45	696	±10
HCC-M52 - 2290	HAB-MH52	HAB-MS52	937	± 9

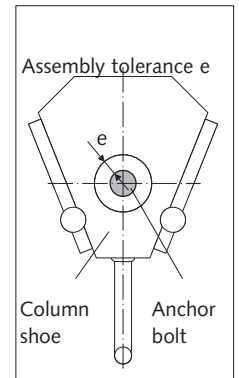

① for column concrete \geq C30/37 acc. to type test certificate.

Additional reinforcement and execution of the lap-over joint for column reinforcement → page 12

② Length L for 'good' anchorage conditions (incl. $1.0 \times f_{bd}$). Also available for 'poor' anchorage conditions on request (incl. $0.7 \times f_{bd}$).

③ Dimension B corresponds to the height of the recess body → page 12.

When designing the column connection, the basic conditions of type test certificate no. 03.30 (for HCC and HCC-M) and approvals Z-21.5-1761 (for HAB-H) and Z.21.5-1758 (for HAB-MH) must be taken into consideration.

HALFEN provides the HCC dimensioning software as a working aid → page 4-5.

TECHNICAL CONSULTATION

HALFEN is represented with sales offices and distributors worldwide.

Please contact us: www.halfen.com → refer to catalogue rear cover.

Materials, Standards

Base plate, side plates	S355J2, DIN EN 10025-2
Reinforcement steel	<ul style="list-style-type: none"> Bar diam. up to 28 mm: BSt 500S, DIN 488-1; (B 500 B) Bar diam. 32 and 40 mm: BSt 500S, acc. to general official approval; (B 500 B)

HALFEN COLUMN SHOE SYSTEM

Anchor bolts

Headed anchor bolt type HAB-H

HALFEN HAB-H Anchor bolts, including 2 nuts + 2 washers

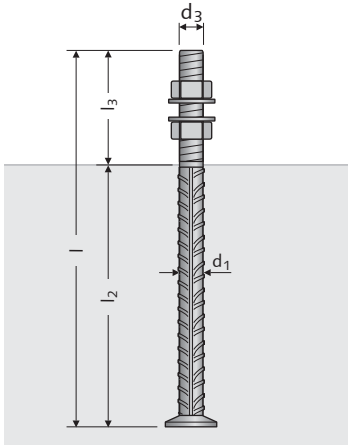

HALFEN Anchor bolts type HAB-H are made of reinforcement steel BSt 500S with rolled thread. Anchoring is achieved by the forged head (headed anchor bolt). The shallow installation depth required for the anchor bolts type HAB-H makes them particularly suitable for anchoring work in large-area components such as foundations or walls with sufficiently large edge distances.

Type selection HAB-H

Item name	Article no.	Length	Installation depth	Thread-length	Anchor bar diameter	Thread diameter	Weight
HAB-H d ₃ TYPE [mm]	0951.010-	l [mm]	l ₂ [mm]	l ₃ [mm]	d ₁ [mm]	d ₃ [mm]	[kg/piece]
HAB-H16	00001	280	175	105	16	16	0.7
HAB-H20	00002	350	235	115	20	20	1.2
HAB-H24	00003	430	300	130	25	24	2.2
HAB-H30	00004	500	350	150	32	30	4.0
HAB-H39	00005	700	535	165	40	39	9.0

Order example:

Anchor bolt type HAB-H20
article no. 0951.010-00002
and the suitable
column shoe type HCC 20-830
article no. 0950.010-00002

Load bearing capacity HAB-H

Item name	Tension/ compression capacity	Transverse pull capacity	Bending load capacity	To be observed:	
				minimum centre spacing s [mm]	minimum edge distance c [mm]
HAB-H16	N _{Rd,s} ① [kN]	V _{Rd,s} ① [kN]	M ⁰ _{Rk,s} ① [Nm]	80	50
HAB-H20	61.7	26	182	100	70
HAB-H24	96.3	40	357	100	70
HAB-H30	138.7	58	617	130	100
HAB-H39	220.4	92	1237	150	130
HAB-H39	383.4	160	2837	150	130

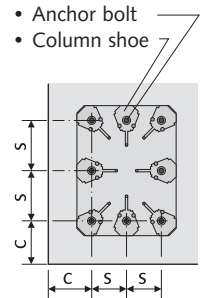

① for concrete ≥ C20/25 and applications in connection with HALFEN HCC Column shoe (→ page 6) according to Approval Z-21.5-1761.

Please enquire about load bearing features for other applications to our sales offices and distributors worldwide. Please contact us: www.halfen.com → refer to catalogue rear cover.

The proof of anchorage in concrete, must be produced according to approval Z-21.5-1761 geometry and structure of the anchorage base taking into account.

HALFEN provides the HCC software (current version) for dimensioning → page 4-5.

Combination with column shoe

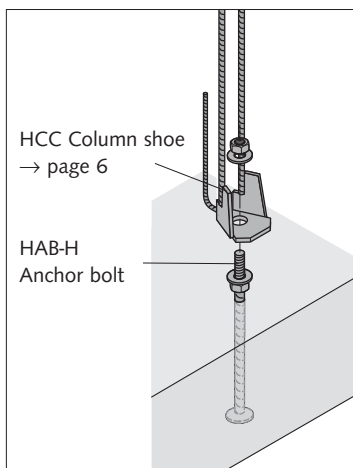

Materials, standards

Anchor bolts	<ul style="list-style-type: none"> Bar diam. d₁ 16 to 25 mm: reinforcement steel BSt 500S, DIN 488-1; (B500 B) Bar diam. d₁ ≥ 32 mm: reinforcement steel BSt 500S, acc. to general official approval; (B500 B)
Hexagon nuts	Strength grade 8, DIN EN 20898-2
Washers	S355J0, DIN EN 10025-2

HALFEN COLUMN SHOE SYSTEM

Anchor bolts

Headed anchor bolt type HAB-MH

HALFEN HAB-MH Anchor bolts, including 2 nuts + 2 washers

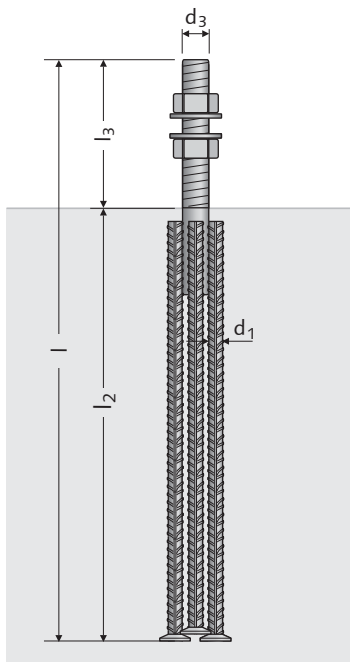

Anchor arrangement:

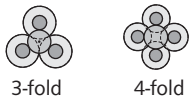

Order example:

Anchor bolt type HAB-MH36
 article no. 0951.030-00004
 and the suitable column shoe
 type HCC-M36-1650
 article no. 0950.010-00007

Combination with column shoe

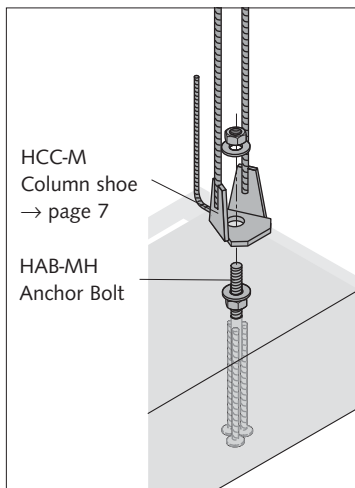

HALFEN Anchor bolts type HAB-MH are made from 2 to 4 headed reinforcement bars which are factory welded to a threaded high-strength steel stud. The shallow installation depth required for the anchor bolts type HAB-MH makes them particularly suitable for anchoring work in large-area components such as foundations or walls with sufficiently large edge distances.

Type selection HAB-MH

Item name	Article no.	Length	Installation depth	Thread-length	No. and diam. anch. bars d ₁	Thread diameter d ₃	Weight
HAB-MH d ₃ TYPE [mm]	0951.030-	l [mm]	l ₂ [mm]	l ₃ [mm]	d ₁ [mm]	d ₃ [mm]	[kg/piece]
HAB-MH30-(36)	00003	755	575	165	4, Ø 20	36	9.5
HAB-MH36	00004	755	575	165	4, Ø 20	36	10.0
HAB-MH39	00005	880	695	185	3, Ø 25	39	13.0
HAB-MH45	00006	980	785	195	4, Ø 25	45	19.0
HAB-MH52	00007	1160	900	240	4, Ø 32	52	34.5

Load bearing capacity HAB-MH

Item name	Tension/compression capacity N _{Rd,s} ① [kN]	Transverse pull capacity V _{Rd,s} ① [kN]	Bending load capacity M ⁰ _{Rk,s} ① [Nm]	To be observed:	
				minimum centre spacing s [mm]	minimum edge distance c [mm]
HAB-MH d ₃ TYPE [mm]	N _{Rd,s} ① [kN]	V _{Rd,s} ① [kN]	M ⁰ _{Rk,s} ① [Nm]	s [mm]	c [mm]
HAB-MH30-(36)	436*	235*	3160*	160	140
HAB-MH36	436	235	3160	160	140
HAB-MH39	520	280	4130	180	150
HAB-MH45	696	376	6390	200	160
HAB-MH52	937	506	9980	280	180

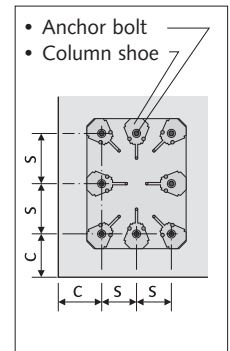

① for concrete ≥ C20/25 and applications in connection with HALFEN HCC-M Column shoe (→ page 7) according to approval Z-21.5-1758.

* Values for bolts as HAB-MH36

Please enquire about load bearing features for other applications to our sales offices and distributors worldwide. Please contact us: www.halfen.com → refer to catalogue rear cover.

The proof of anchorage in concrete, must be produced according to Approval Z-21.5-1758 geometry and structure of the anchorage base taking into account. HALFEN provides the HCC software (current version) for dimensioning → page 4-5.

Materials, standards

Anchor bolts	<ul style="list-style-type: none"> Bar diam. d₁ 16 to 25 mm: reinforcement steel BSt 500S, DIN 488-1; (B500B) Bar diam. d₁ ≥ 32: reinforcement steel BSt 500S, acc. to general official approval; (B500 B)
Threaded component	High strength steel, e.g. Imacro M acc. to material specification sheet MS Imacro Ø 36, Ø 39, Ø 45, Ø 52
Hexagon nuts	Strength grade 10, DIN EN 20898-2
Washers	S355J0, DIN EN 10025-2

HALFEN COLUMN SHOE SYSTEM

Anchor bolts

Straight anchor bolt type HAB-S

HALFEN HAB-S Anchor bolt, including 2 nuts + 2 washers

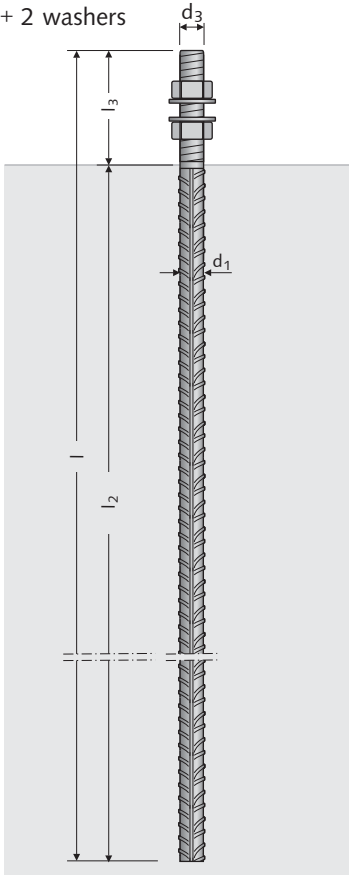

HALFEN Anchor bolts type HAB-S are made of reinforcement steel grade BSt 500S with rolled thread. Anchorage is made by overlapping joint or anchoring according to reinforced concrete standards, enabling minimum centre spacings and edge distances. HAB-S Anchor bolts are also available with bent or angled end on request.

Type selection HAB-S

Item name	Article no.	Length	Installation depth	Thread length	Anchor bar diameter	Thread diameter	Weight
HAB-S d ₃ TYPE [mm]	0951.020-	l [mm]	l ₂ [mm]	l ₃ [mm]	d ₁ [mm]	d ₃ [mm]	[kg/piece]
HAB-S16	00001	970	865	105	16	16	1.7
HAB-S20	00002	1170	1055	115	20	20	3.1
HAB-S24	00003	1360	1230	130	25	24	5.6
HAB-S30	00004	1660	1510	150	32	30	11.0
HAB-S39	00005	1980	1815	165	40	39	20.5

Load bearing capacity HAB-H

Item name	Tension/compression capacity	Transverse pull capacity	Bending load capacity
HAB-S d ₃ TYPE [mm]	N _{Rd,s} ① [kN]	V _{Rd,s} ① [kN]	M ⁰ _{Rk,s} ① [Nm]
HAB-S16	61.7	26	182
HAB-S20	96.3	40	357
HAB-S24	138.7	58	617
HAB-S30	220.4	92	1237
HAB-S39	383.4	160	2778

Anchorage acc. to DIN 1045-1 or EC2

Order example:

Anchor bolt Type HAB-S20
 article no. 0951.020-00002
 and the suitable
 column shoe Type HCC 20-830
 article no. 0950.010-00002

Combination with column shoe

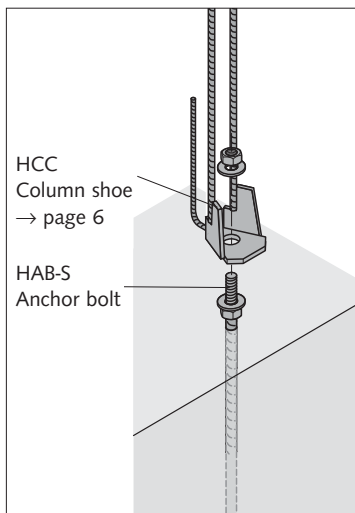

① for concrete ≥ C20/25 and applications in connection with HALFEN HCC Column shoe (→ page 6).

Please enquire about load bearing features for other applications to our sales offices and distributors worldwide. Please contact us: www.halfen.com → refer to catalogue rear cover.

HALFEN provides the dimensioning software HCC as a working aid for the anchorage proof in concrete using straight bar ends, see → pages 4-5.

Materials, standards

Anchor bolts	<ul style="list-style-type: none"> • Bar diam. d1 16 to 25 mm: reinforcement steel BSt 500S, DIN 488-1; (B500 B) • Bar diam. d1 ≥ 32 mm: reinforcement steel BSt 500S, acc. to general official approval; (B500 B)
Hexagon nuts	Strength grade 8, DIN EN 20898-2
Washers	S355J0, DIN EN 10025-2

HALFEN COLUMN SHOE SYSTEM

Anchor bolts

Straight anchor bolt type HAB-MS

HALFEN HAB-MS Anchor bolt, including 2 nuts + 2 washers

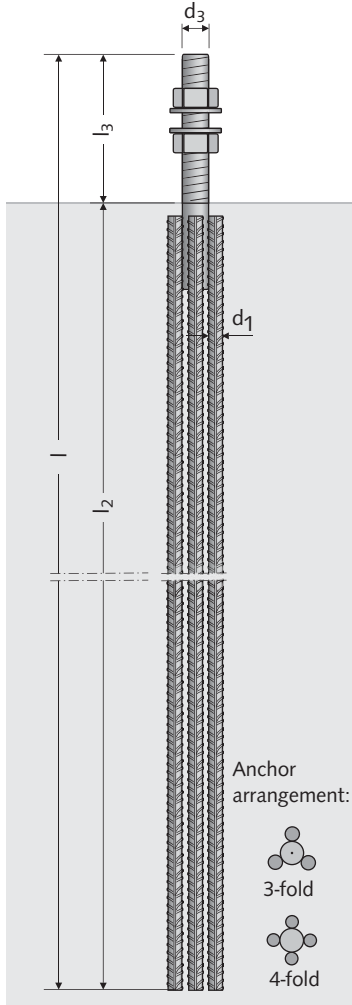

HALFEN HAB-MS Anchor bolts are made from 2 to 4 ribbed reinforcement bars which are factory welded to a threaded high-strength steel stud. The anchorage is made by overlapping joint or anchoring according to the reinforced concrete standards. This enables minimum centre spacings and edge distances. HAB-MS Anchor bolts are also available with bent or angled bars on request.

Type selection HAB-MS							
Item name	Article no.	Length	Installation depth	Thread-length	No. and diam. anch. bars	Thread diameter	Weight
HAB-MS d ₃ TYPE [mm]	0951.040-	l [mm]	l ₂ [mm]	l ₃ [mm]	d ₁ [mm]	d ₃ [mm]	[kg/piece]
HAB-MS30-(36)	00003	1430	1265	165	4, Ø 20	36	15.5
HAB-MS36	00004	1430	1265	165	4, Ø 20	36	16.0
HAB-MS39	00005	1600	1415	185	3, Ø 25	39	21.0
HAB-MS45	00006	1800	1605	195	4, Ø 25	45	31.5
HAB-MS52	00007	1910	1670	240	4, Ø 32	52	52.0

Load bearing capacity HAB-MS			
Item name	Tension/compression capacity	Transverse pull capacity	Bending load capacity
HAB-MS d ₃ TYPE [mm]	N _{Rd,s} ① [kN]	V _{Rd,s} ① [kN]	M ⁰ _{Rk,s} ① [Nm]
HAB-MS30-(36)	436*	235*	3160*
HAB-MS36	436	235	3160
HAB-MS39	520	280	4130
HAB-MS45	696	376	6390
HAB-MS52	937	506	9980

Anchorage acc. to DIN 1045-1 or EC2

① for concrete ≥ C20/25 and applications in connection with HALFEN Column shoe HCC-M (→ page 7).
* Values for bolts as HAB-MS36

Please enquire about load bearing features for other applications to our sales offices and distributors worldwide. Please contact us: www.halfen.com → refer to catalogue rear cover.

HALFEN provides the dimensioning software HCC as a working aid for the anchorage proof in concrete using straight bar ends, see → pages 4-5.

Combination with column shoe

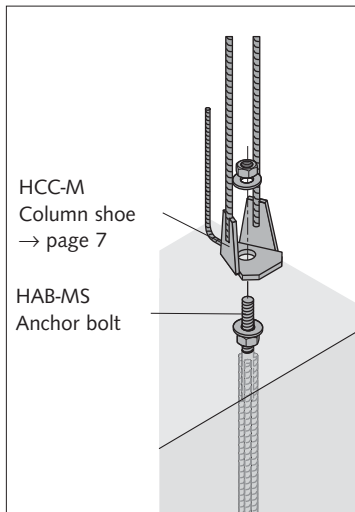

Materials, standards	
Anchor bolts	• Bar diam. d ₁ 16 to 25 mm: reinforcement steel BSt 500S, DIN 488-1; (B 500 B) • Bar diam. d ₁ ≥ 32: reinforcement steel BSt 500S, acc. to general official approval; (B 500 B)
Threaded component	High strength steel, e.g. Imacro M acc. to material specification sheet MS Imacro Ø 36, Ø 39, Ø 45, Ø 52
Hexagon nuts	Strength grade 10, DIN EN 20898-2
Washers	S355J0, DIN EN 10025-2

HALFEN COLUMN SHOE SYSTEM

Application

Fitting the HCC Column shoes into the formwork

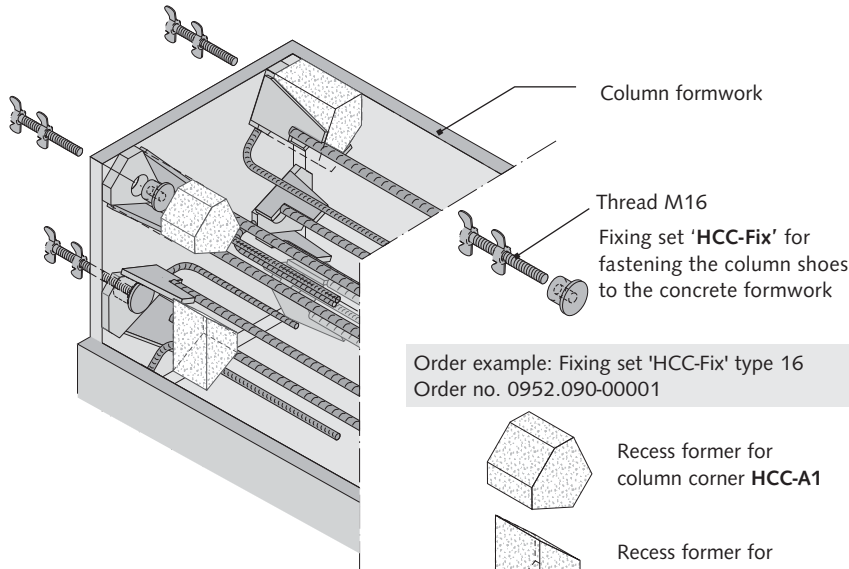

Order example: Fixing set 'HCC-Fix' type 16
Order no. 0952.090-00001

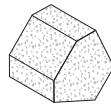

Recess former for column corner **HCC-A1**

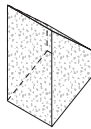

Recess former for column edge **HCC-A2**

Order example: Recess former type HCC-A2-16
Order no. 0952.020-00001

Fixing set 'HCC-Fix' suitable for HCC type:	article no.
HCC-Fix type 16	00001
HCC-Fix type 20	00002
HCC-Fix type 24	00003
HCC-Fix type 30	00004
HCC-Fix type 39/M36/M39	00005
HCC-Fix type M30	00006
HCC-Fix type M45	00007
HCC-Fix type M52	00008

Recess formers HCC A1 und HCC A2 suitable for HCC type:	for corner A1 article no.	for edge A2 article no.
HCC - A ... - 16	0952.010-00001	0952.020-00001
HCC - A ... - 20	00002	00002
HCC - A ... - 24	00003	00003
HCC - A ... - 30	00004	00004
HCC - A ... - 39	00005	00005
HCC - A ... - M30	00006	00006
HCC - A ... - M36	00007	00007
HCC - A ... - M39	00008	00008
HCC - A ... - M45	00009	00009
HCC - A ... - M52	00010	00010

Additional reinforcement example

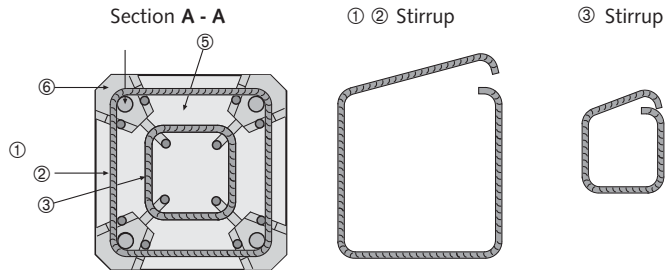
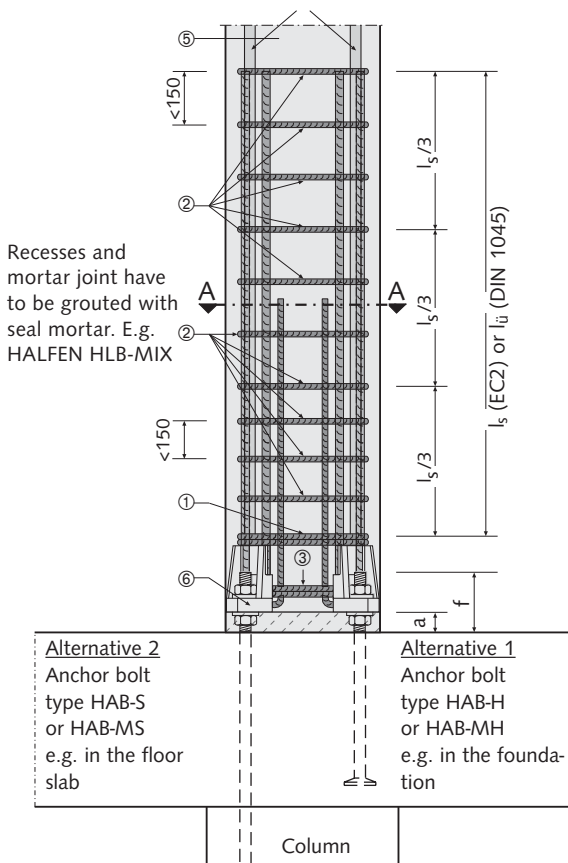

- ① Stirrup for column shoe
 - ② Stirrup in the joint area
 - ③ Stirrup for column shoe bar
 - ④ Longitudinal reinforcement in the corner area
 - ⑤ Column concrete
 - ⑥ HCC Column shoe
- Additional stirrups in the column shoe area

Column shoe	Anchor bolt	①	②	③
HCC - 16	HAB-H16 / HAB-S16	1 Ø 8	Ø 8	1 Ø 8
HCC - 20	HAB-H20 / HAB-S20	1 Ø 10	Ø 10	1 Ø 10
HCC - 24	HAB-H24 / HAB-S24	1 Ø 10	Ø 10	1 Ø 10
HCC - 30	HAB-H30 / HAB-S30	1 Ø 12	Ø 12	1 Ø 12
HCC - 39	HAB-H39 / HAB-S39	2 Ø 12	Ø 12	2 Ø 12
HCC - M30	HAB-MH30-(36)/HAB-MS30-(36)	2 Ø 10	Ø 10	2 Ø 10
HCC - M36	HAB-MH36/HAB-MS36	2 Ø 12	Ø 12	2 Ø 12
HCC - M39	HAB-MH39/HAB-MS39	2 Ø 12	Ø 12	2 Ø 12
HCC - M45	HAB-MH45/HAB-MS45	3 Ø 12	Ø 12	3 Ø 12
HCC - M52	HAB-MH52/HAB-MS52	3 Ø 12	Ø 12	3 Ø 12

HALFEN COLUMN SHOE SYSTEM

Application

Installing HAB Anchor bolts

Fitting template

The most practical way to fit the HAB Anchor bolts into the concrete formwork is the use of a fitting template. The template is used to screw the individual bolts into the concrete formwork at the same height with the 2 nuts and washers provided, they are then aligned correctly to axis and vertically, and secured against displacement during the concreting process.

The template is reusable.

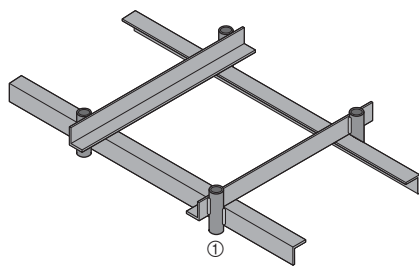

Fitting template: Sturdy welded steel structure: dimensions and number of positioning sleeves ① according to order specifications.

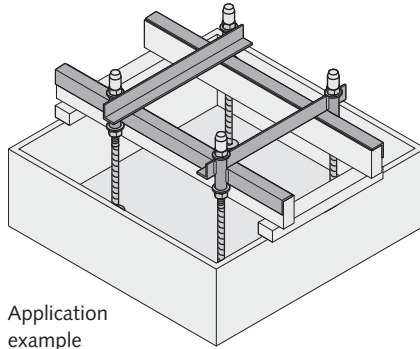

Application example

Assembly cap

The steel assembly cap protects the thread of the anchor bolt from damage during assembly.

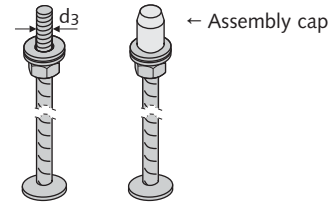

Assembly caps	suitable to d3	article no.
Item name	[mm]	0952.060-
HCC-MKA - 16	16	00001
HCC-MKA - 20	20	00002
HCC-MKA - 24	24	00003
HCC-MKA - 30	30	00004
HCC-MKA - 36	36	00005
HCC-MKA - 39	39	00006
HCC-MKA - 45	45	00007
HCC-MKA - 52	52	00008

Installing the precast column

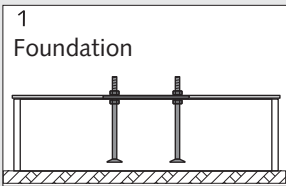
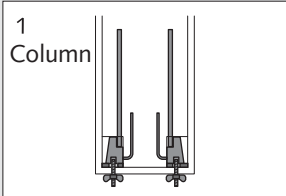

Column:

- Attach the column shoe to the head plate of the formwork.

Foundation:

- Fit the anchor bolts into the foundation formwork using the template.

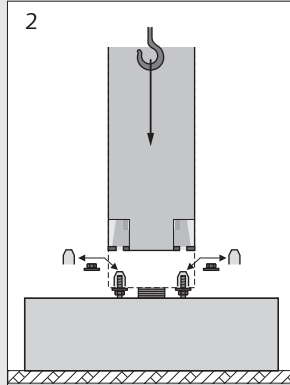

- Remove the template, insert the assembly plates, put the assembly caps in place.
- Set the column down. Remove the assembly caps, screw the top nuts with the washers onto the anchor bolts.
- Adjust and calibrate the column.
- Tighten the nuts. A defined turning moment is not required.

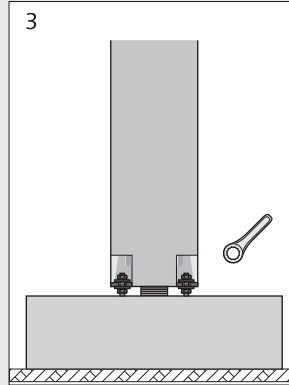

- The column is connected force-locked with the foundation (assembly state).
- The dimensions of the recesses allow the use of ring type slugging wrenches.
- The foot of the column and the recesses must be filled with low-shrink seal mortar e.g. HALFEN HLB-MIX according to the mortar manufacturer's specification.
- Mortar strength at least column concrete strength.

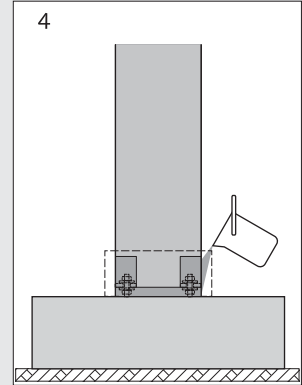

- This filling process can take place via a casting pipe inserting into the column or a casting pocket on the concrete formwork.
- The joint mortar has to be filled at one side only in order to guarantee complete and even casting without any hollow spaces.

HALFEN COLUMN SHOE SYSTEM

Application

Application examples

Coupling of precast reinforced concrete columns

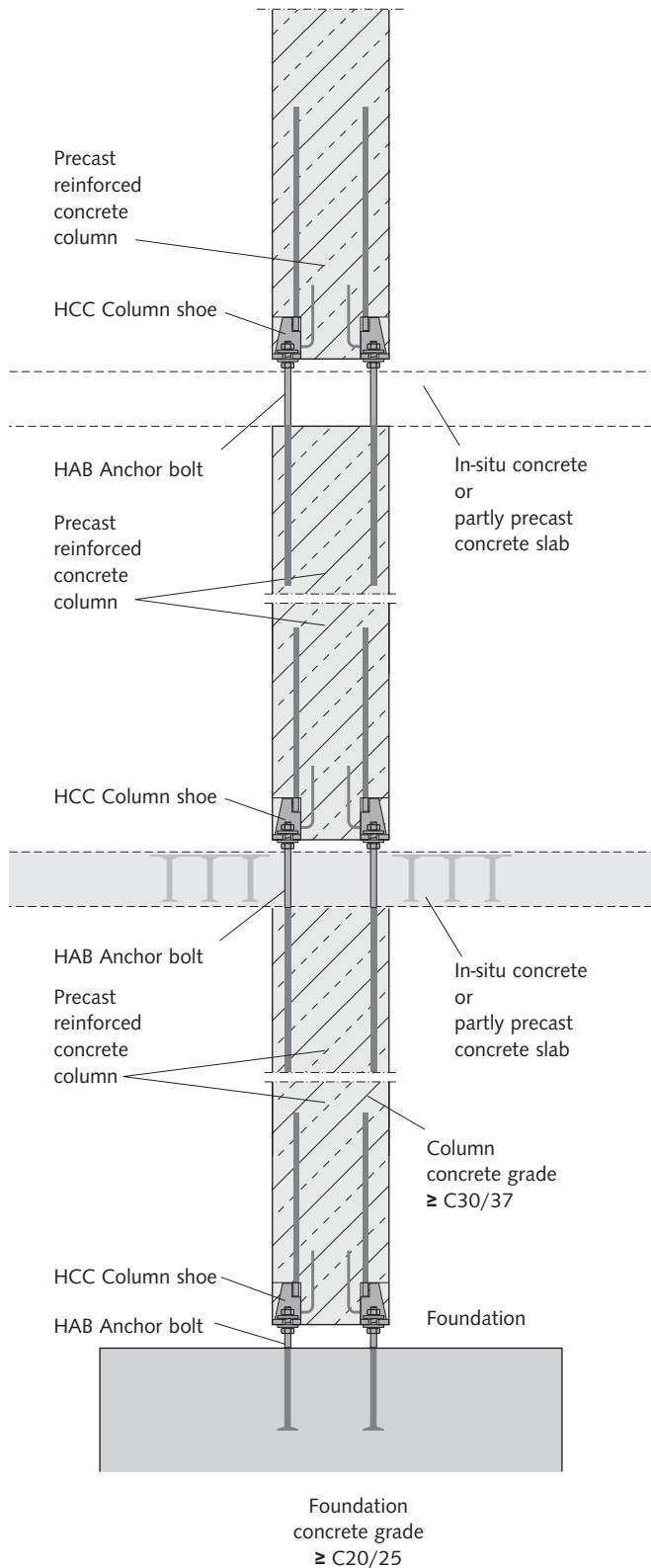

HALFEN HCC Column shoes are also used for continuous columns which can be prepared as precast parts independently from the floors. The precast reinforced concrete columns are one storey high, the connection between the columns is rigid using HALFEN Column shoes and anchor bolts.

Filling the joint at column base with seal mortar

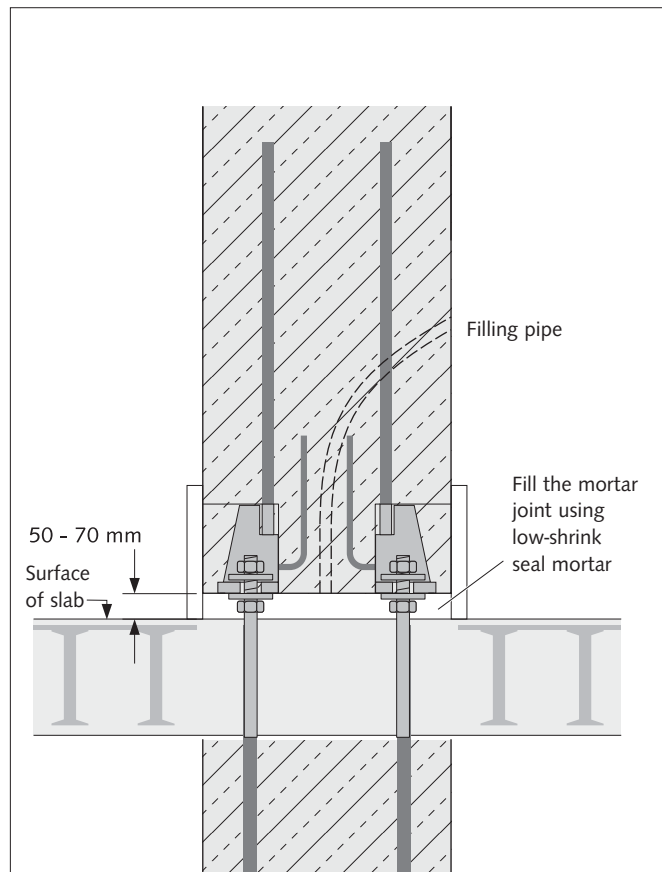

The mortar joint under the column is made of low-shrink seal mortar of at least the same strength class as the concrete column. The full final load bearing capacity is only given if this casting process is followed. HALFEN seal mortar HLB-MIX is available in 25 kg bags. article no. 0058.060-00001

HALFEN COLUMN SHOE SYSTEM

Application

On the construction site: fast and safe assembly using the HALFEN Column shoe system



The anchor bolts are cast in into the foundation at the exact position, using a fitting template, and . . .



. . . the column can be set up directly on the foundation, once the concrete is cured.

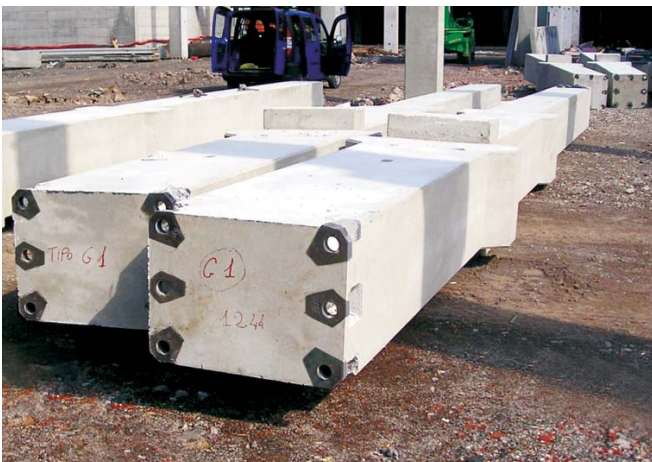

The concrete columns, fitted with the HALFEN Column shoes, are supplied to the site ready-to-assemble.



HALFEN Column shoes ensure an efficient installation process, . . .



. . . structurally efficient connections, and . . .



. . . interfering assembly braces are redundant.

CONTACT HALFEN WORLDWIDE

HALFEN is represented by subsidiaries in the following 14 countries, please contact us:

Austria	HALFEN Gesellschaft m.b.H. Leonard-Bernstein-Str. 10 1220 Wien	Phone: +43 - 1 - 259 6770 E-Mail: office@halfen.at Internet: www.halfen.at	Fax: +43 - 1 - 259 - 6770 99
Belgium/Luxembourg	HALFEN N.V. Borkelstraat 131 2900 Schoten	Phone: +32 - 3 - 658 07 20 E-Mail: info@halfen.be Internet: www.halfen.be	Fax: +32 - 3 - 658 15 33
China	HALFEN Construction Accessories Distribution Co.Ltd. Room 601 Tower D, Vantone Centre No.A6 Chao Yang Men Wai Street Chaoyang District Beijing · P.R. China 100020	Phone: +86 - 10 5907 3200 E-Mail: info@halfen.com Internet: www.halfen.cn	Fax: +86 - 10 5907 3218
Czech Republic	HALFEN-DEHA s.r.o. K Vypichu 986 · Komerční zóna Rudná, hala 6 25219 Rudná	Phone: +420 - 311 - 690 060 E-Mail: info@halfen-deha.cz Internet: www.halfen-deha.cz	Fax: +420 - 311 - 671 416
France	HALFEN S.A.S. 18, rue Goubet 75019 Paris	Phone: +33 - 1 - 445231 00 E-Mail: halfen@halfen.fr Internet: www.halfen.fr	Fax: +33 - 1 - 445231 52
Germany	HALFEN Vertriebsgesellschaft mbH Katzbergstrasse 3 40764 Langenfeld	Phone: +49 - 2173 - 970 0 E-Mail: info@halfen.de Internet: www.halfen.de	Fax: +49 - 2173 - 970 225
Italy	HALFEN S.r.l. Soc. Unipersonale Via F.lli Bronzetti N° 28 24124 Bergamo	Phone: +39 - 035 - 0760711 E-Mail: info@halfen.it Internet: www.halfen.it	Fax: +39 - 035 - 0760799
Netherlands	HALFEN b.v. Oostermaat 3 7623 CS Borne	Phone: +31 - 742 - 6714 49 E-Mail: info@halfen.nl Internet: www.halfen.nl	Fax: +31 - 742 6726 59
Norway	HALFEN AS Postboks 2080 4095 Stavanger	Phone: +47 - 51 82 34 00 E-Mail: post@halfen.no Internet: www.halfen.no	Fax: +47 - 51 82 34 01
Poland	HALFEN Sp. z o.o. Ul. Obornicka 287 60-691 Poznan	Phone: +48 - 61 - 622 14 14 E-Mail: info@halfen.pl Internet: www.halfen.pl	Fax: +48 - 61 - 622 14 15
Spain	HALFEN S.L. c/ Fuente de la Mora 2, 2° D 28050 Madrid	Phone: +34 - 91 - 632 18 40 E-Mail: info@halfen.es Internet: www.halfen.es	Fax: +34 - 91 - 633 42 57
Sweden	Halfen AB Box 150 435 23 Mölnlycke	Phone: +46 - 31 - 98 58 00 E-Mail: info@halfen.se Internet: www.halfen.se	Fax: +46 - 31 - 98 58 01
Switzerland	HALFEN Swiss AG Hertistrasse 25 8304 Wallisellen	Phone: +41 - 44 - 849 78 78 E-Mail: mail@halfen.ch Internet: www.halfen.ch	Fax: +41 - 44 - 849 78 79
United Kingdom / Ireland	HALFEN Ltd. Humphrys Road · Woodside Estate Dunstable LU5 4TP	Phone: +44 - 1582 - 47 03 00 E-Mail: info@halfen.co.uk Internet: www.halfen.co.uk	Fax: +44 - 1582 - 47 03 04

Furthermore HALFEN is represented with sales offices and distributors worldwide. Please contact us: www.halfen.com

NOTES REGARDING THIS CATALOGUE

Technical and design changes reserved. The information in this publication is based on state-of-the-art technology at the time of publication. We reserve the right to make technical and design changes at any time. HALFEN GmbH shall not accept liability for the accuracy of the information in this publication or for any printing errors.

The Quality Management System of Halfen GmbH is certified for the locations in Germany, Austria, Poland, Switzerland and the Czech Republic according to **DIN EN ISO 9001:2008**, Certificate No. QS-281 HH.

